

PATENT ABSTRACTS OF JAPAN

(11)Publication number : 2003-190235

(43)Date of publication of application : 08.07.2003

(51)Int.Cl. A61H 1/02
A63B 23/04

(21)Application number : 2001-401369

(71)Applicant : IJIMA SHUNICHI

(22)Date of filing : 28.12.2001

(72)Inventor : IJIMA SHUNICHI

(54) ANKLE TURNING HEALTH DEVICE

(57)Abstract:

PROBLEM TO BE SOLVED: To provide a small ankle turning health device, allowing freely selecting of a rotating angle (size of rotation), rotating direction and the like of a foot with one driving source in an ankle turning exercise having various effects in respect of health, simple in structure and inexpensively manufacturable.

SOLUTION: In two right and left foot placing plates to which a sole projecting on a case with the toe on the upper side is made to adhere and fixed, the upper end parts of rods penetrating a top plate of the case are respectively fixed to the heel area thereof, and spherical parts whose outer peripheries are expanded to be spherical are formed on the upper sides of the middle parts of the rods. The spherical parts are supported by spherical bearings mounted on the top plate of the case, and the lower sides of the rods hung down in the case are freely rocked in four ways. The lower sides of both rods mesh with gears driven by a motor and simultaneously engage with eccentric positions of two right and left rotary disks rotated horizontally. Both disks are provided on an elevating support plate, and the support plate is installed in a slide box capable of moving forward and backward in the case.

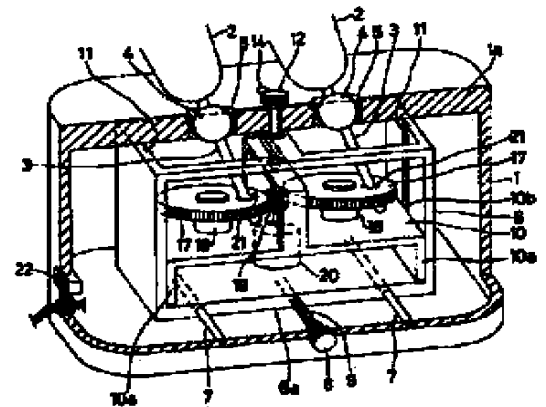

* NOTICES *

JPO and INPIT are not responsible for any damages caused by the use of this translation.

- 1.This document has been translated by computer. So the translation may not reflect the original precisely.
- 2.**** shows the word which can not be translated.
- 3.In the drawings, any words are not translated.

CLAIMS

[Claim(s)]

[Claim 1]An upper bed part of a rod which inserts a top plate of **** into a heel of a footrest board of two right and left which can adhesion fix the sole which turns a tiptoe part up and projects on ****, respectively is fixed, A spherical portion of this rod which the periphery bulges above pars intermedia, respectively, and makes the shape of a ball is formed, This spherical portion is supported by spherical bearing provided in a **** top plate, and a lower part of a rod which hangs in **** is constituted on all sides, enabling free rocking, it engages with an eccentric position of a rotating disc of two right and left which a lower part of both the above-mentioned rods gears with a gear driven on a motor, and carry out horizontal rotation simultaneously, these both disks are provided on a support plate which can go up and down, and it comes to install this support plate within **** in a slide box in which back and forth movement is possible -- carrying out an ankle time -- a healthy machine.

[Claim 2]The Claim 1 description engaged by inserting the lower part in a circular hole established in an eccentric position of said rotating disc loosely carries out an ankle time, and said each rod is a healthy machine.

[Claim 3]Insertion support of said slide box is carried out at a guide lever in which the bottom plate carried out the diameter to a **** inner bottom in order, It is thrust into a front center section of the bottom plate of the above-mentioned slide box by cross direction, Claim 1 which constitutes the above-mentioned slide box by rotating operation of this knob so that back and forth movement is possible, or 2 descriptions carry out an ankle time, and a screwed shaft of a knob which can be freely rotated in a front face of a pars basilaris ossis occipitalis of **** is a healthy machine.

[Claim 4]As for a support plate with which a horizontal rotation disk of said right and left is provided, the whole makes transverse-plane facing-down KO type, A downward side board formed in the both sides ****s to a right-and-left wall of said slide box, This screwed shaft lower part of a knob on **** provided with a screwed shaft which inserts inside of a long groove established in the center section of the **** top plate inserts into an opening surface center section of the above-mentioned slide box a center section of the strip which carried out diameter immobilization in order, The above-mentioned support plate is hung to screw in the above-mentioned support plate center section at a cross direction with an engaging plate which carried out protrusion immobilization, descriptions to Claim 1 which constitutes this support plate within a slide box by rotating operation of the above-mentioned knob on **** so that rise and fall are possible, 2, or 3 carry out an ankle time, and it is a healthy machine.

[Claim 5]Said right-and-left rod of each other which attached a footrest board to an upper bed part is constituted by slidable inside-and-outside double pipe, descriptions to Claim 1 which comes to form in a lower end of this rod inner tube a sphere supported by spherical bearing provided in an eccentric position of said rotating disc, 3, or 4 carry out an ankle time, and it is a healthy machine.

[Claim 6]Spherical bearing provided in right and left of a **** top plate comes to support a spherical portion formed in pars intermedia of a rod of two right and left which attached a footrest board to an upper bed part, pull in a lower end part of the above-mentioned rod which can be freely rocked within ****, and one end of a coil spring is attached, and it comes to fix the other end to a component in which vertical position regulation is possible within **** -- carrying out an ankle time -- a healthy machine.

[Translation done.]

* NOTICES *

JPO and INPIT are not responsible for any damages caused by the use of this translation.

- 1.This document has been translated by computer. So the translation may not reflect the original precisely.
- 2.**** shows the word which can not be translated.
- 3.In the drawings, any words are not translated.

DETAILED DESCRIPTION

[Detailed Description of the Invention]

[0001]

[Field of the Invention]An ankle is turned in this invention.

Therefore, it is a thing which can improve the blood flow of the whole leg, can relieve the fatigue of a lower half of the body, and can also cancel MUKUMI of a leg carry out an ankle time and concerning a healthy machine.

[0002]

[Description of the Prior Art]If an ankle is turned when it is standing all day long, or you walk and the leg is tired, anyone may be sufficient as the ability to relieve the fatigue of the whole leg, and it is just going to experience, and a healthy effect can expect it enough for a bedridden person also by light movement which turns an ankle small.

[0003]although there are few machines to which made it make the ankle torsion which has an effect in such recovery from fatigue, health promotion, the compensation for lack of exercise, etc. perform compulsorily, for example, there are also what gives movement which moves a tiptoe to order or a longitudinal direction conventionally, and a thing which uses many motors in order to turn an ankle in various directions, There was no small effective instrument which performs the ankle torsion in arbitrary angles and directions by one set of a drive motor.

[0004]

[Problem to be solved by the invention]this invention is a small thing in which the structure it enabled it to choose freely is easy for, and can manufacture inexpensive the ankle torsion which has various effects as mentioned above in a healthy side by one driving source for angle of rotation (rotational size) of a leg, revolving speed, a hand of cut, etc. and which carries out an ankle time and proposes a healthy machine.

[0005]

[Means for solving problem]Namely, this invention fixes the upper bed part of the rod which inserts the top plate of **** into the heel of the footrest board of two right and left which can adhesion fix the sole which turns a tiptoe part up and projects on ****, respectively, The spherical portion of this rod which the periphery bulges above pars intermedia, respectively, and makes the shape of a ball is formed, This spherical portion is supported by the spherical bearing provided in the **** top plate, and the lower part of the rod which hangs in **** is constituted on all sides, enabling free rocking, It engages with the eccentric position of the rotating disc of two right and left which the lower part of both the above-mentioned rods gears with the gear driven on a motor, and carry out horizontal rotation simultaneously, It is a thing characterized by providing these both disks on the support plate which can go up and down, and coming to install this support plate within **** in the slide box in which back and forth movement is possible carry out an ankle time and concerning a healthy machine. Hereafter, a figure explains the embodiment of this invention.

[0006]

[Mode for carrying out the invention]Drawing 1 is a perspective view concerning this invention in which carrying out an ankle time and showing an example of the appearance of a healthy machine, and **** (case) which builds in the drive mechanism which carries out the postscript of 1, and 2 are the footrest boards of two right and left installed so that it might project on this **** 1, they turned the tiptoe side up, received vertically, and are somewhat projected with the angle. It can be considered as sandals with the heel as shown in a figure, or a slippers type, or these footrest boards 2 and 2 may enable it to bind the instep side tight by two belts with a surface fastener or a buckle so that the adhesion immobilization of the sole of right-and-left both legs can be carried

out, respectively.

[0007] Drawing 2 - 3 are what shows the drive mechanism of the footrest board formed in **** 1, 3 is a rod which inserts the top plate 1a which constitutes **** 1, and, as for the footrest boards 2 and 2 on either side, the upper bed part of this rod 3 is fixed to the heel, The spherical portion 4 which a periphery bulges in the pars intermedia upper part of this rod 3, and makes the shape of a ball is formed, and this spherical portion 4 is supported by the surface-of-a-sphere bearing 5 provided in the top plate 1a of **** 1, and comprises a lower part of the rod 3 which hangs in **** 1 by making this spherical portion 4 into a fulcrum on all sides, enabling free rocking. Since it has planned making both legs circle in the heel as a center in this invention, respectively, it is so good that the distance of the spherical portion 4 and the heel of the footrest board 2, i.e., the length above the spherical portion 4 of the rod 3, is short (for example, about 1-2 cm).

[0008] 6 is the slide box ****(ed) in **** 1, insertion support of the bottom plate 6a is carried out at the two guide levers 7 and 7 by which diameter immobilization was carried out in order at **** 1 inner bottom, and this slide box 6 is constituted by the cross direction movable. 8 is a knob provided with the screwed shaft 9 for slide box order **, and this knob 8 rotates in the front face of **** 1 pars basilaris ossis occipitalis in homotopic, The screwed shaft 9 is thrust into the front center section of the bottom plate 6a of the slide box 6 by the cross direction, by turning the knob 8 with a finger, it can show around at the above-mentioned guide lever 7, and only prescribed distance can carry out now slide movement of the slide box 6 to order.

* NOTICES *

JPO and INPIT are not responsible for any damages caused by the use of this translation.

- 1.This document has been translated by computer. So the translation may not reflect the original precisely.
- 2.**** shows the word which can not be translated.
- 3.In the drawings, any words are not translated.

DESCRIPTION OF DRAWINGS

[Brief Description of the Drawings]

[Drawing 1]It is an appearance perspective view concerning this invention in which carrying out an ankle time and showing an example of a healthy machine.

[Drawing 2]It is a perspective view concerning this invention in which carrying out an ankle time and showing the inner structure of a healthy machine.

[Drawing 3]They are said and a transverse-plane explanatory view.

[Drawing 4]The state concerning this invention where carried out the ankle time, and a turning direction and the turning radius of (b) are in the usual state, and the turning radius of (**) is usual, lengthened the rotating disc to the front in the operation explanatory view of the healthy machine, and the turning direction was put to sleep is shown.

[Drawing 5]The state and (**) concerning this invention which carried out the ankle time, and a turning direction is in the usual state, and (b) raised the rotating disc, and extended the turning radius in the operation explanatory view of the healthy machine show the state where lengthened the rotating disc to the front, and made it go up, and put the turning direction to sleep, and the turning radius was extended.

[Drawing 6]It is a transverse-plane explanatory view concerning this invention in which carrying out an ankle time and showing the important section of other working examples of a healthy machine.

[Drawing 7]It is a transverse-plane explanatory view concerning this invention in which carrying out an ankle time and showing the important section of the working example of further others of a healthy machine.

[Explanations of letters or numerals]

1-****

2-footrest board

3-rod

4-spherical portion

5-spherical bearing

6-slide box

7-guide lever

The knob for 8-slide box order **

9-screwed shaft

10-support plate

11-guide rail

The knob for 12-support plate rise and fall

13-screwed shaft

14-long groove

15-strip

16-engaging plate

17-rotating disc

18-pivot

19-driver

20-deceleration motor

21-eccentricity circular hole

22-electric power switch

The knob for 23-speed controls

The sphere of 24-rod lower end

25-spherical bearing
26-tension coil spring
27-support plate

[Translation done.]

(19) 日本国特許庁 (J P)

(12) 公開特許公報 (A)

(11) 特許出願公開番号

特開2003-190235

(P2003-190235A)

(43) 公開日 平成15年7月8日(2003.7.8)

(51) Int.Cl.⁷

識別記号

F I

テマコード^{*}(参考)

A 6 1 H 1/02

A 6 1 H 1/02

N

A 6 3 B 23/04

A 6 3 B 23/04

Z

審査請求 未請求 請求項の数 6 O L (全 6 頁)

(21) 出願番号

特願2001-401369(P2001-401369)

(71) 出願人 502005017

飯嶋 俊一

山梨県都留市法能2494番地2

(22) 出願日

平成13年12月28日(2001. 12. 28)

(72) 発明者 飯嶋 俊一

山梨県都留市法能2494番地2

(74) 代理人 100078709

弁理士 浅賀 一樹

(54) 【発明の名称】 足首回し健康器

(57) y v æ

y	エ	N	°	-	X	±	°	繰
⊕	'	fi	"	-	«	æ] p	季
x	A	æ] β	"	'	R	I	置
"	P	-	¿	»		∅	<	遊
∅	B							
Y		± z			a		~	
S	-	L	'	¥	"	¶ E Q		繰
	V	')	• ∅	b	連
h	»	⊕ ... ⊕				a β		動
"	•	'	"	'	<	‡ ⊕ A Y		器
°	†	x	‡	⊕ A				器
β	h	fi	'	¥	<	‡ ⊕ A		器
		fi	‡	⊕ ∅		~		器
		æ] ~		S	°	u	重
"	x	'	a		fl	⊕ A Y		盛
¥	"	X	C h			u	‡	盛

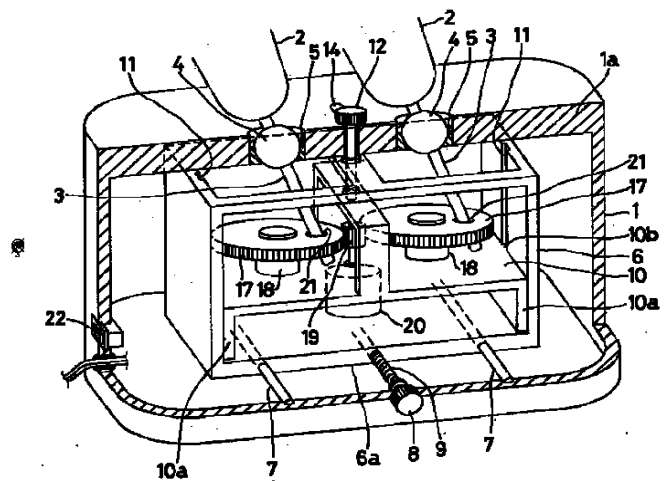

» Ø Y b h R a 運
 a ß " O " c 息
 < † € A Y \ ' S " 宜
 † fl T x † € A 運
 ß - " Y \ S x 運
 € ~ † Ø B " n A { > - 運
 ~ ø æ † " Ø - ~ Ø } 運
 " ' Q ø " Z † 運
 a / • † " Z † 運
 y O O O W z U " P 運
 Y X C h U " » € ' 運
 • n - L † € % Q { K 運
 ~ † ~ O a ß C h O 運
 † X 1 f Ø X C h O 運
 W " P € O ° n † 運
 † X " X C h U € ' 運
 L K C h W V ~ † € ~ 運
 £ fl X C h fi † " Ø 運
 Ø B
 Y O O O X z P O " a L X 運
 ¥ " † ° " « R \ ' " 運
 E ... / " « / ' P O U 運
 / / ' A Y X C h O ° 運
 o P O " ~ • Ø a " 運
 < † € 運
 y O O P O z P Q " P 運
 J a % • a P S x ' 運
 P R " B " O L X C h 運
 • n - L % ' P T O 運
 L x / P O / ' W A Y 運
 « R \ P O L " W A Y 運
 x / P O L " W A Y 運
 £ A W ' P U ~ x 運
 € A % O L % X C h 運
 P S - ' P Q C h l 運
 £ A » O a fi £ " Y 運
 † € 運
 y O O P P z P V " a L x 運
 % B P V æ] ' ' Q 運
 P V A P V - L x † P W 運
 V / P O ' / Ø ¶ E O P 運
 Ø a i [n † ~ Y ° † 運
 ' / ... A - € Ø - 運
 ~ † € 運
 y O O P Q z P X " ¶ E 運

° fl " ° • Ø fi 運
 P O " ° a « 運

(5)

J Q O O R 墨

7

8

v f • † 8

Y

P |

Q | « ”

R | h

S | `

T | †

U | X 𐄂

V | K 𐄂W

W | X C h 𐄂

X | 𐄂

P O | ẋ

P P | ~ a

P Q | x 𐄂

P R | 𐄂

P S †

P T |

P U | W

P V | æ

P W †

P X | fi

Q O | ,

10

y) Q

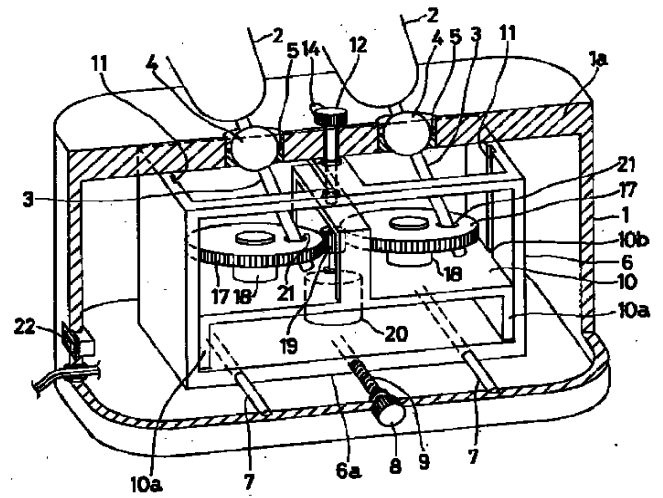
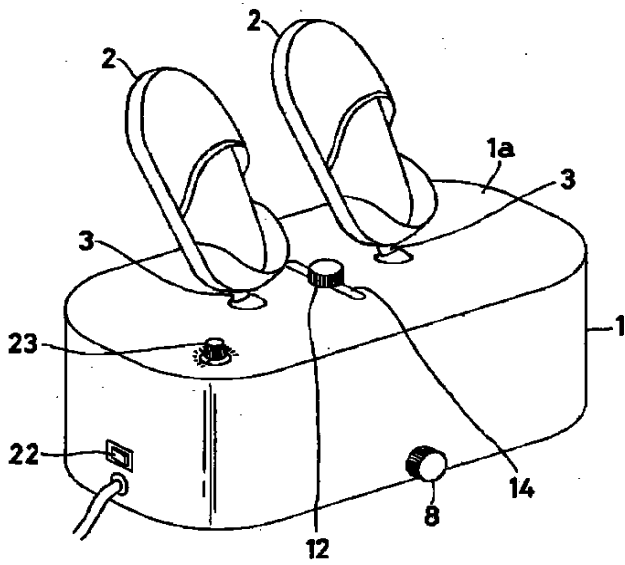

y) R

y) S

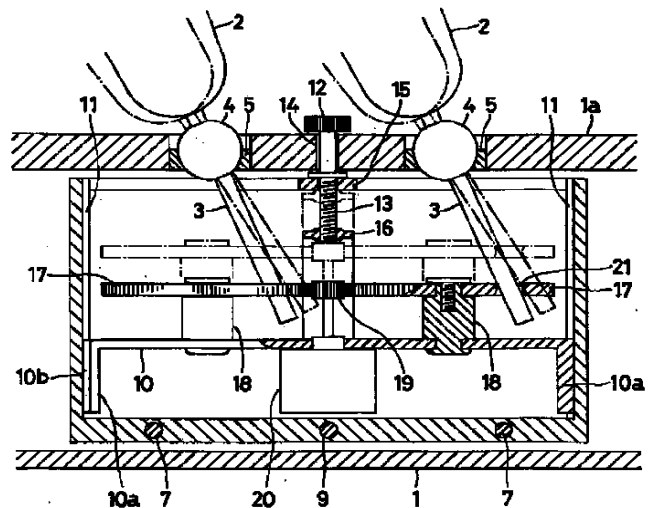
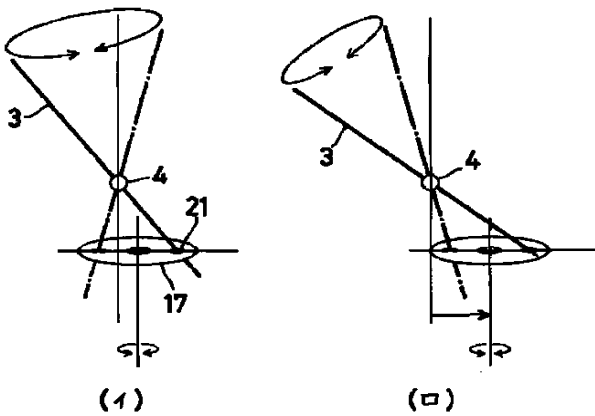

Y } Z

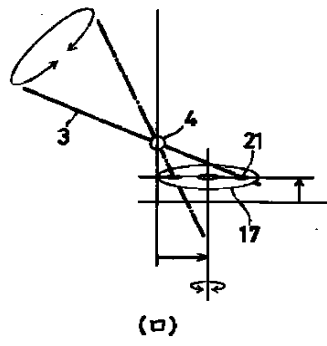
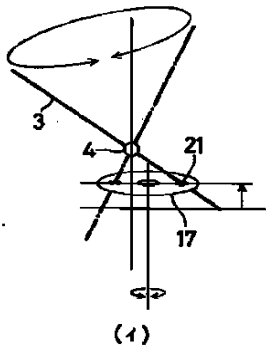

Y } Z

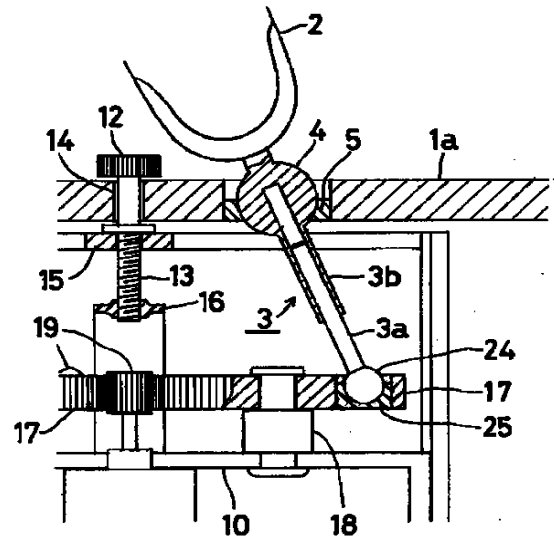

Y } Z

